

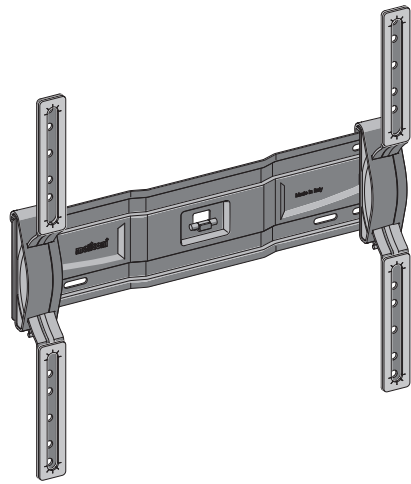

SLIMSTYLE PLUS 400ST



- IT ISTRUZIONI DI MONTAGGIO
- FR INSTRUCTIONS DE MONTAGE
- EN MOUNTING INSTRUCTIONS
- DE MONTAGEANLEITUNG
- NL MONTAGEVOORSCHRIFT
- ES GUÍA DE MONTAJE
- PT INSTRUÇÕES DE MONTAGEM
- EL ΟΔΗΓΙΕΣ ΣΥΝΑΡΜΟΛΟΓΗΣΗΣ
- RU ИНСТРУКЦИИ ПО УСТАНОВКЕ
- PL INSTRUKCJA MONTAŻU
- CZ NÁVOD K MONTÁŽI
- RO INSTRUCȚIUNI DE MONTARE
- HU SZERELÉSI ÚTMUTATÓ
- SE MONTERINGSANVISNINGAR
- NO MONTERINGSINSTRUKSJONER
- FI ASENNUSOHJEET



Qualità certificata
Certified quality



Meliconi S.p.A. - V. Minghetti, 10
40057 Cadrano di Granarolo E. (BO) Italy
www.meliconi.com e-mail: info@meliconi.com

IT Attrezzatura per montaggio **FR** Outils d'assemblage **EN** Assembly equipment **ES** Herramientas de montaje

IT Dati tecnici **FR** Caractéristiques techniques **EN** Technical data **ES** Datos técnicos

40" - 82" / 102 - 208 cm
TV MAX 45 kg / 99 lbs
400ST 1,5 kg / 3.3 lbs
VESA Max 400 mm X Max 400 mm

L4459288, L6928036, L7605005, T1 (x4), T2 (x4), L4459288, TV (x4) OPTIONAL, Ø6 Ø8, L4500032 (x4), Ø6 Ø8

1:1

T1 (x4) Ø5 x 50 L4468138
T2 (x4) Ø8 L4468138

TV (x4) Ø8 x 15 L4459513
TV (x4) Ø6 x 15 L4459513

TV (x4) Ø6 x 16 L7950244
Ø6 x 30 L7950139
Ø8 x 20 L7950137
Ø8 x 30 L7950203

1 (x4)

2 TV (x4) TV (x4) OPTIONAL Ø6 Ø8

2a **2b**

3 a b c

4 **5** **6**

UP

OK!

CURVED TV

4 (x4) X+Y

5 60 mm (2.4") Ø 8 mm max 12 mm (0.5") (x4)

6 T2 (x4) (x4)

4 (x4) X+Y

5 Ø 2,5 mm 60 mm (2.4") max 12 mm (0.5") (x4)

6 T1 (x4) (x4) T2 (x4)

