

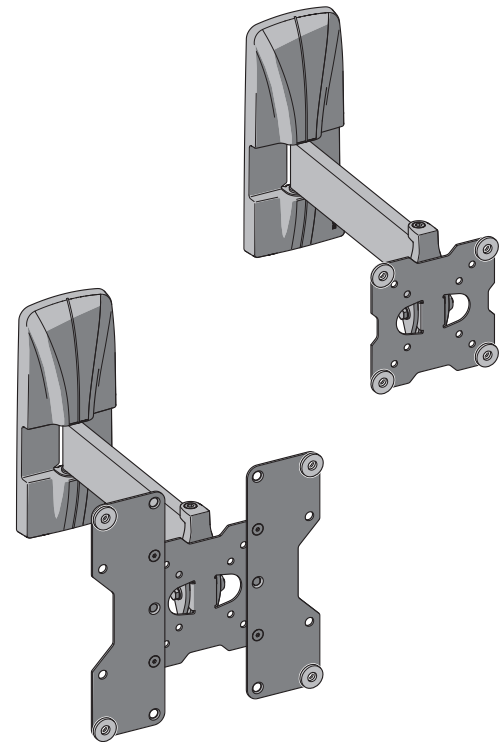

SLIMSTYLE PLUS

100200 SR



IT ISTRUZIONI DI MONTAGGIO
FR INSTRUCTIONS DE MONTAGE
EN MOUNTING INSTRUCTIONS
DE MONTAGEANLEITUNG
NL MONTAGEVOORSCHRIFT
ES GUÍA DE MONTAJE
PT INSTRUÇÕES DE MONTAGEM
EL ΟΔΗΓΙΕΣ ΣΥΝΑΡΜΟΛΟΓΗΣΗΣ
RU ИНСТРУКЦИИ ПО УСТАНОВКЕ
PL INSTRUKCJA MONTAŻU
CZ NÁVOD K MONTÁŽI
RO INSTRUCȚIUNI DE MONTARE
HU SZERELÉSI ÚTMUTATÓ
SE MONTERINGSANVISNINGAR
NO MONTERINGSINSTRUKSJONER
FI ASENNUSOHJEET

Meliconi S.p.A. - V. Minghetti, 10
40057 Cadriano di Granarolo E. (BO) Italy
www.meliconi.com e-mail: info@meliconi.com



IT Dati tecnici FR Caractéristiques techniques EN Technical data ES Datos técnicos

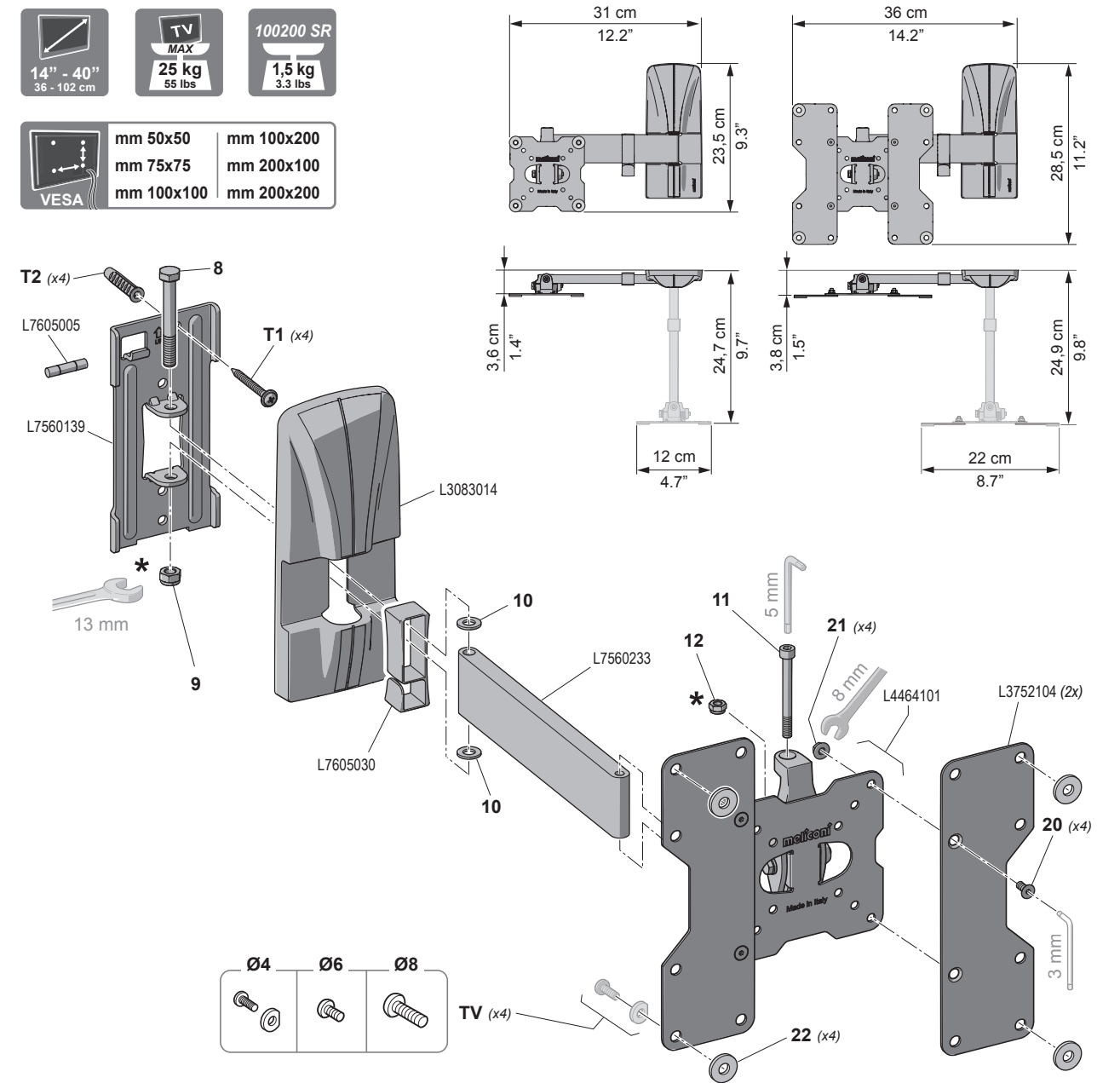

***** IT Dado autobloccante, specifico per evitare svitamenti accidentali. Avvitare in maniera decisa, con gli appositi attrezzi, anche dopo aver avvertito la prima resistenza.
FR Écrou autobloquant, conçu pour éviter tout desserrage accidentel. Serrez fermement, avec les outils appropriés, même après avoir perçu la première résistance.
EN Self-locking nut, designed to prevent accidental loosening. Tighten firmly, with the correct tools, even after feeling the first resistance.
ES Tuerca autobloqueante para evitar que se afloje. Enrosca a fondo con las herramientas específicas, incluso después de haber notado la resistencia inicial.

